



Russian AA lorry. Mod.1915

GM107 1/35

AA gun 76,2mm on the White truck. Putiloff plant

Attention! Some details in the instructions may differ in terms of equipment. These are kits of several individual parts or complex designs with combined parts.

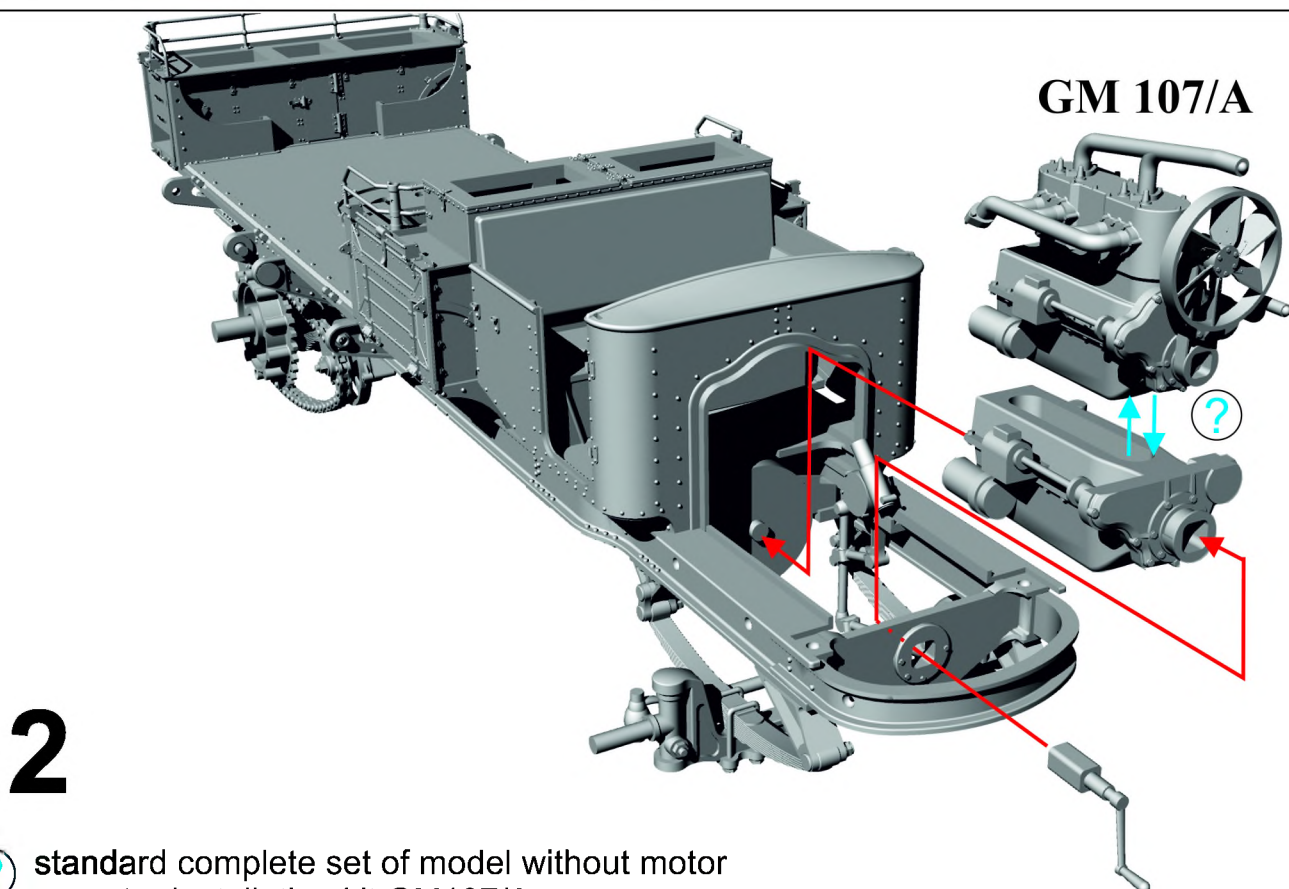
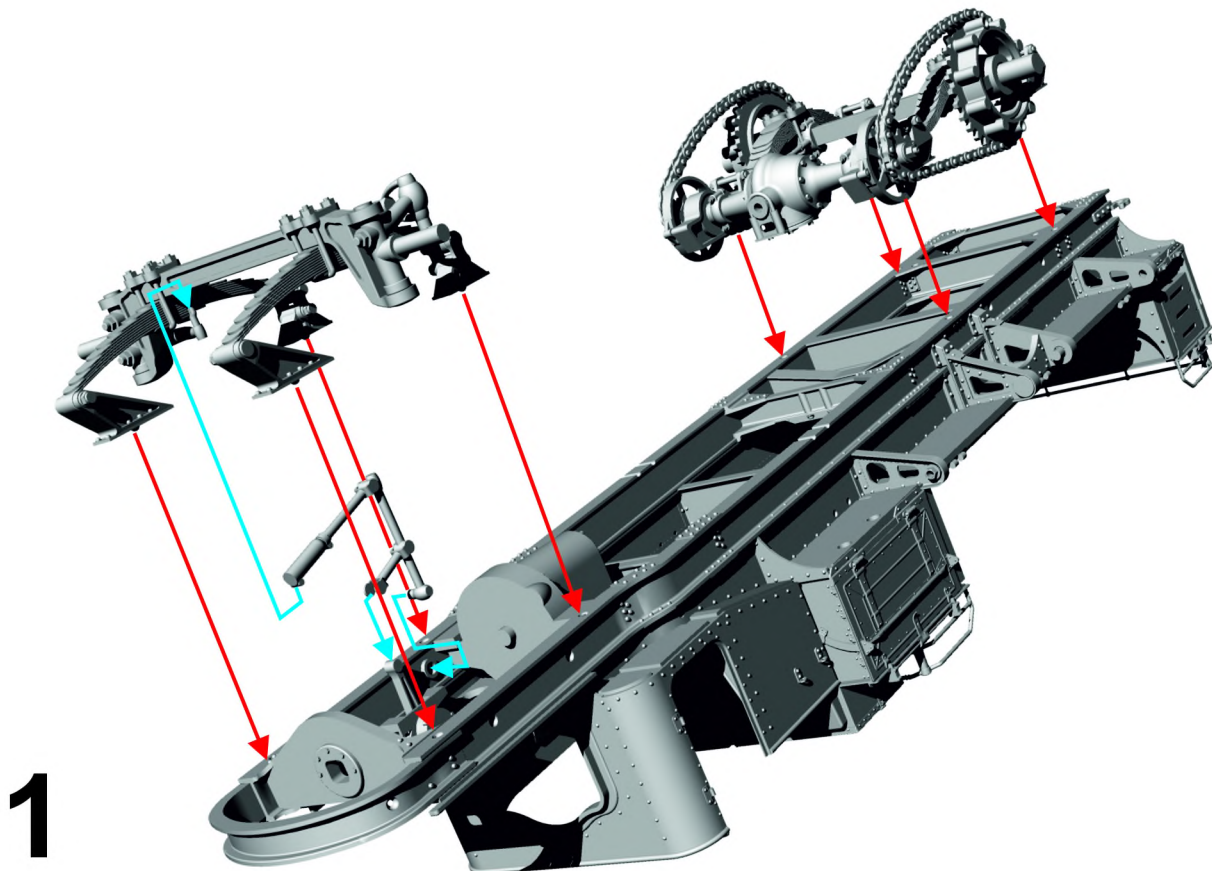

standard complete set of model without motor or motor installation kit GM107/A

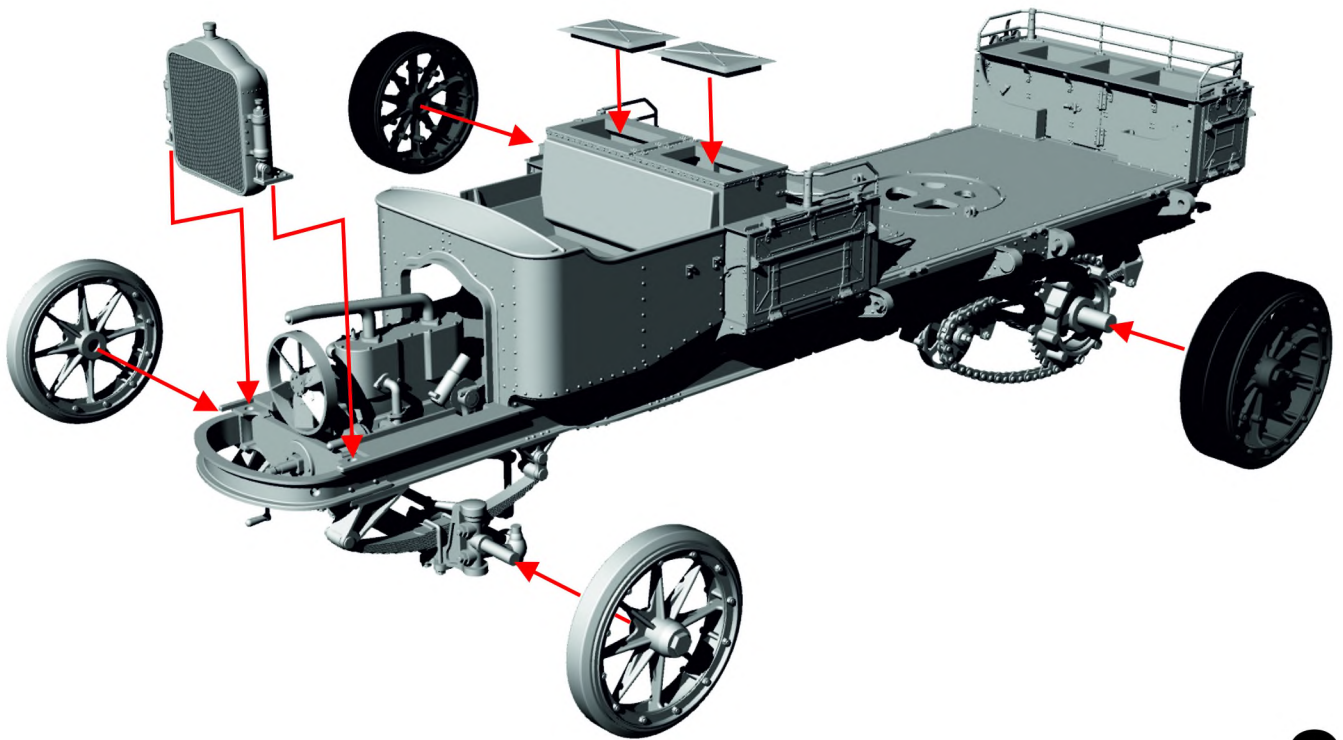

3

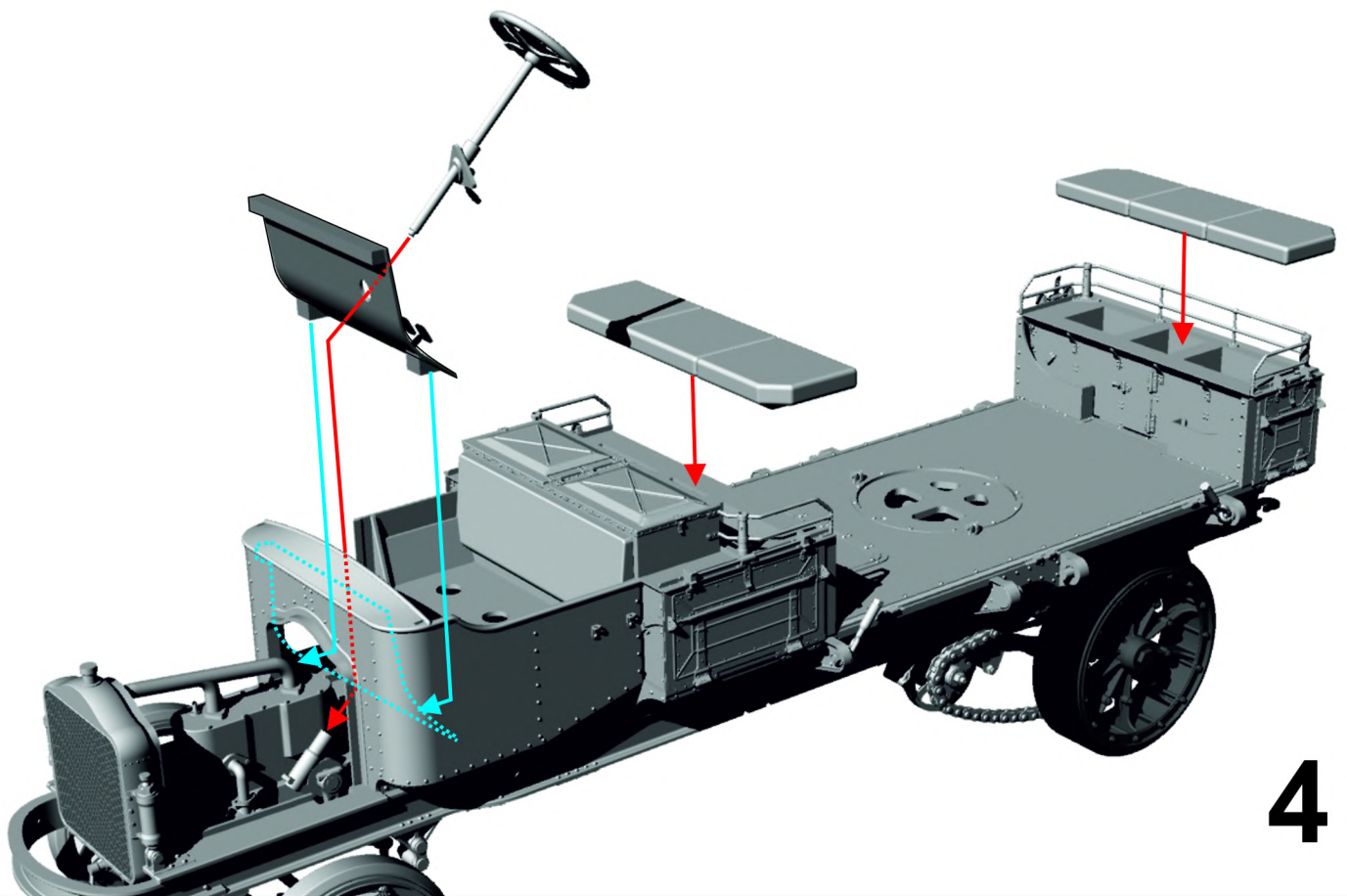

4



Russian AA lorry. Mod.1915

GM107 1/35

AA gun 76,2mm on the White truck. Putiloff plant

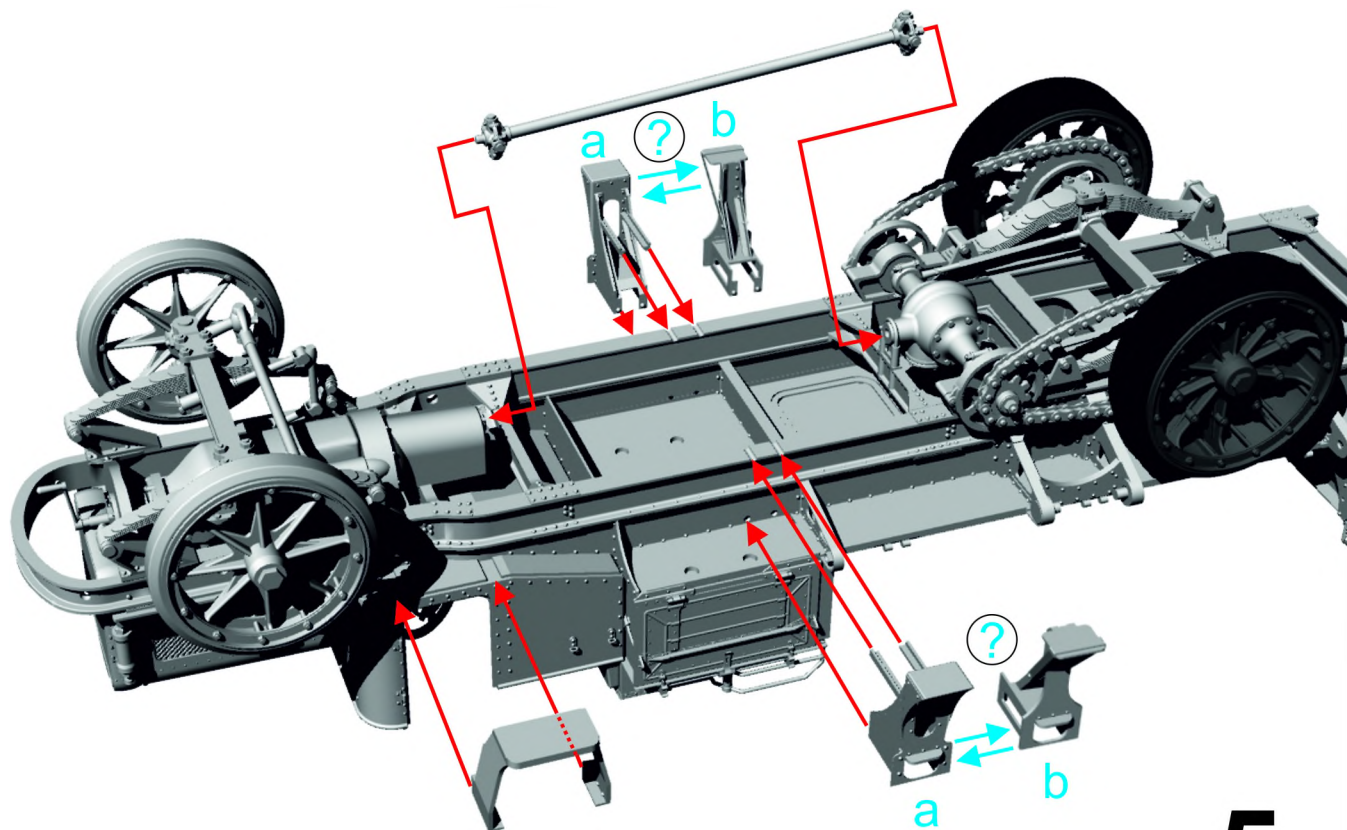

a - late version, mod.1917

b - early version for the Russian Imperial Army, mod.1916

5

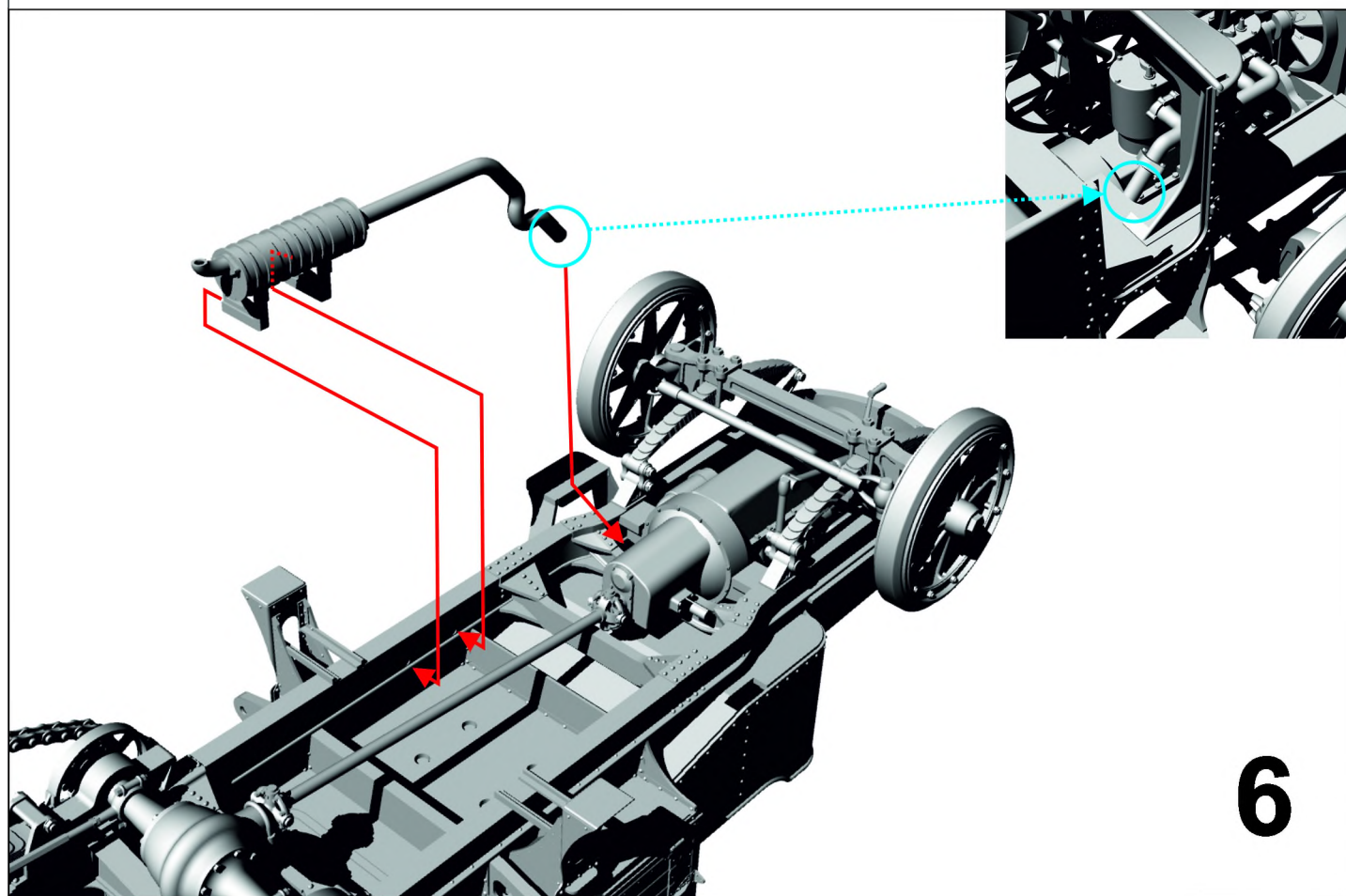

6

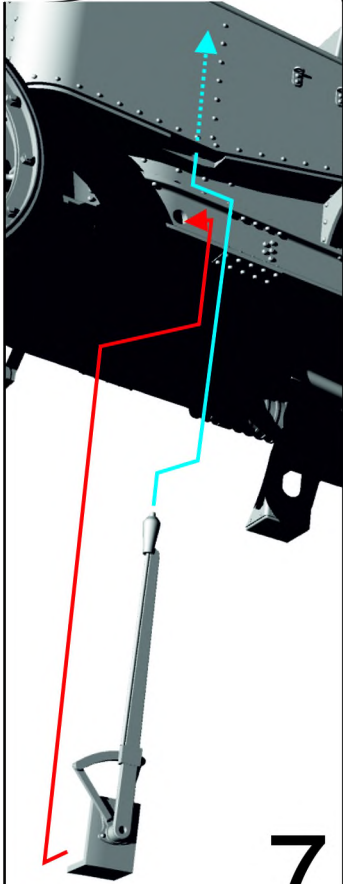

7

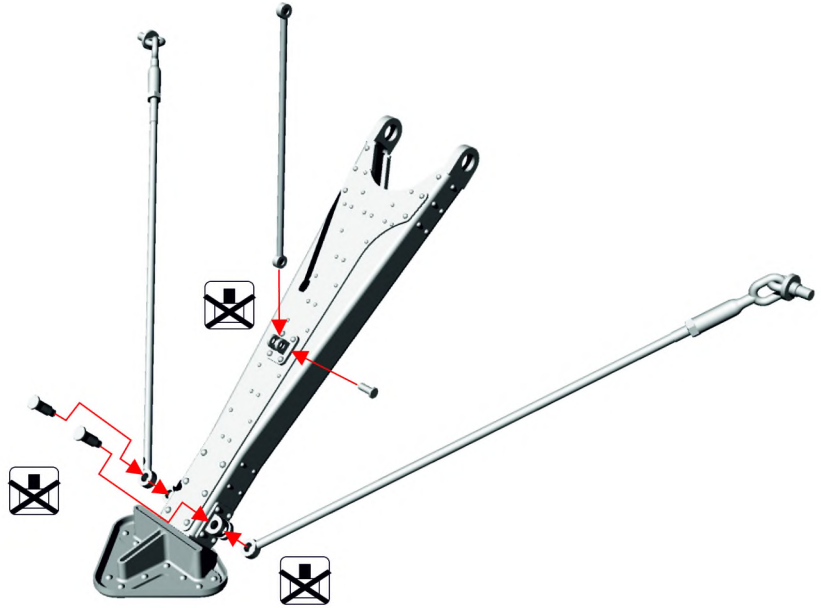

8

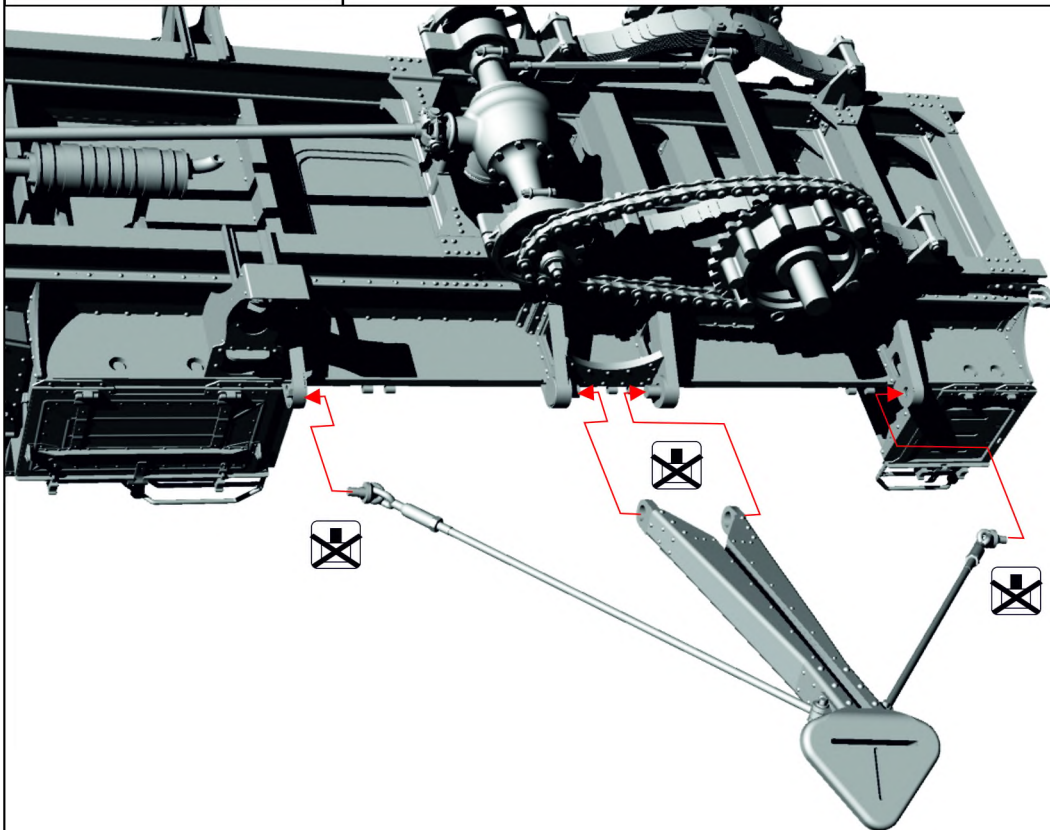

9



10

⚠ Assembly steps are numbered.
Repeat the assembly
of the same design on the other side.

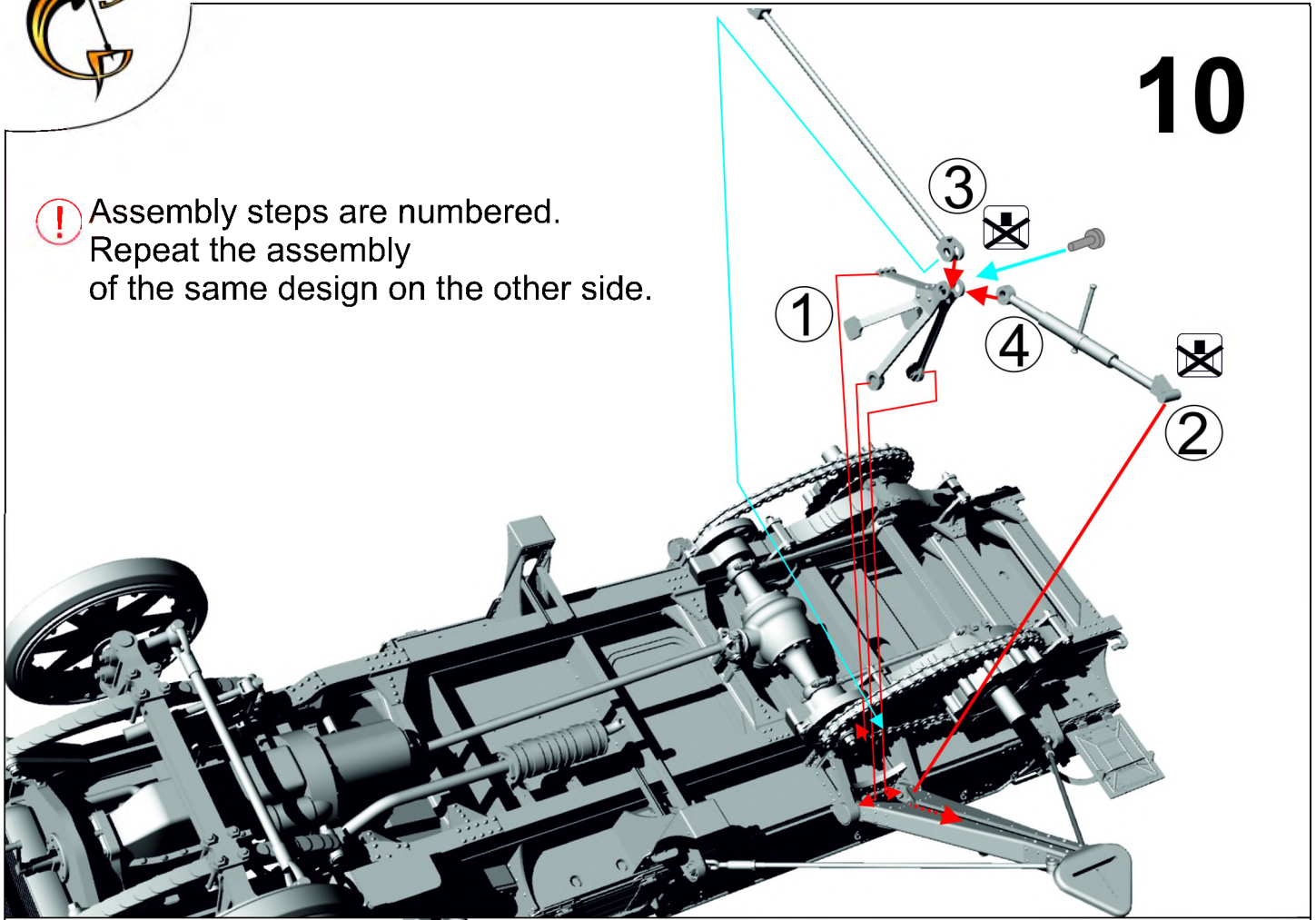

General view of the structure

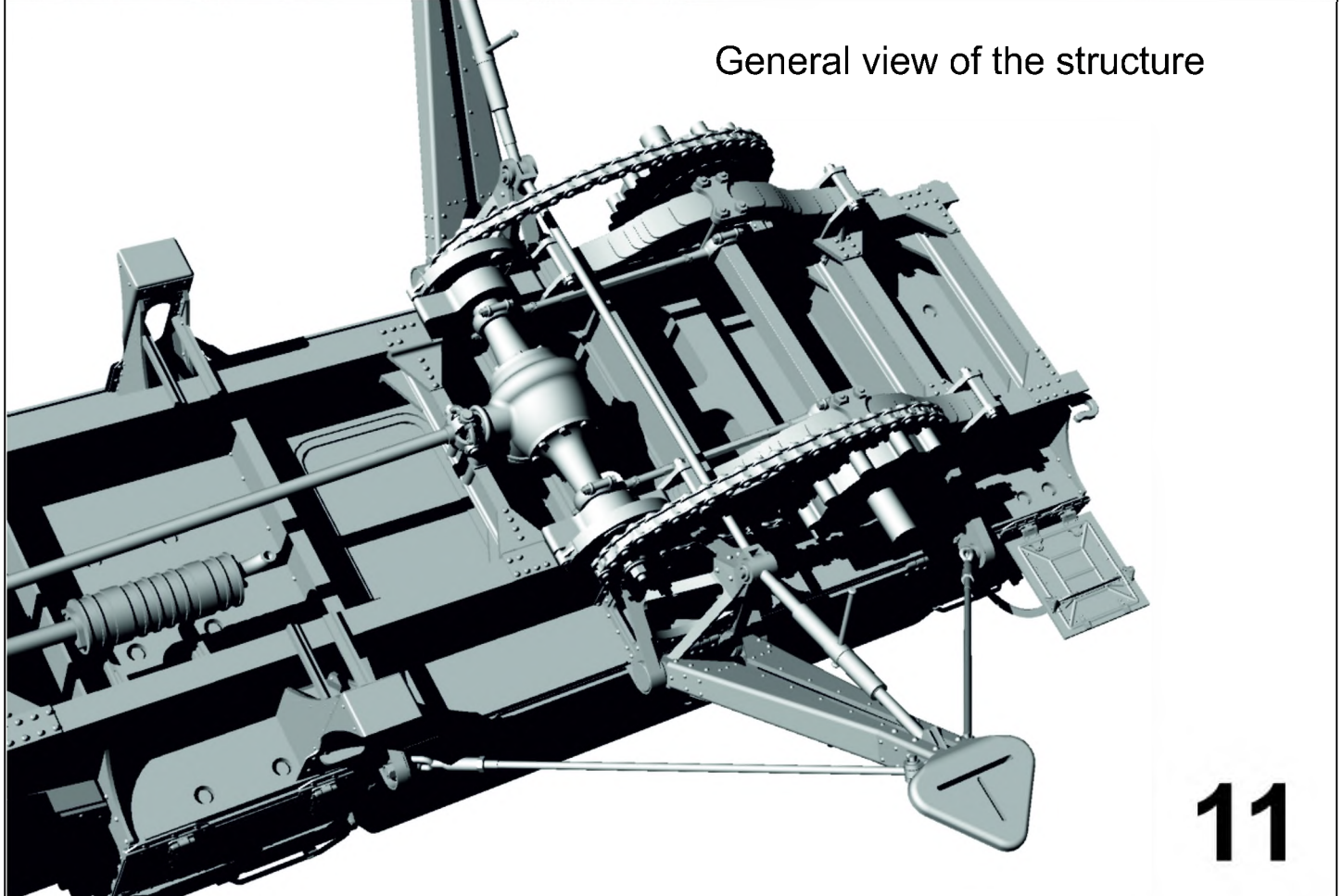

11



12

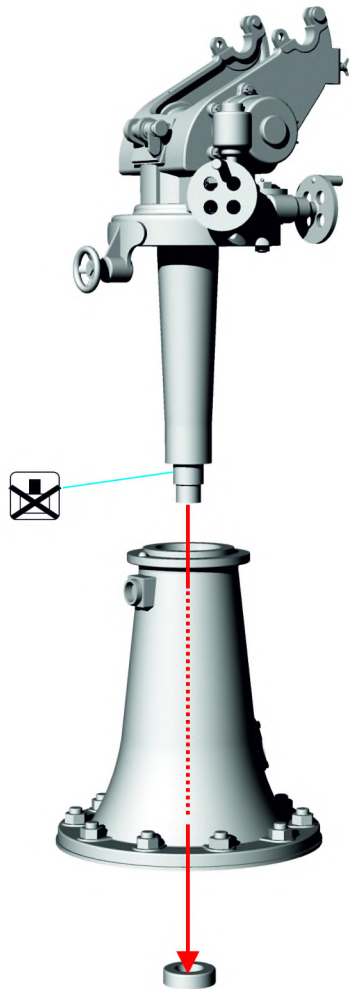

13

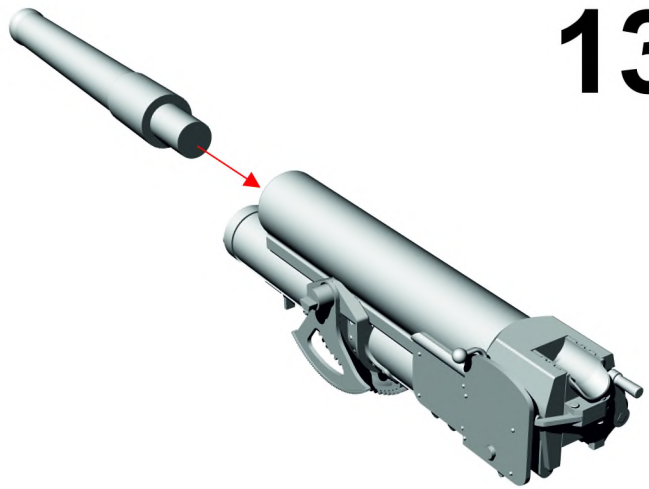

14

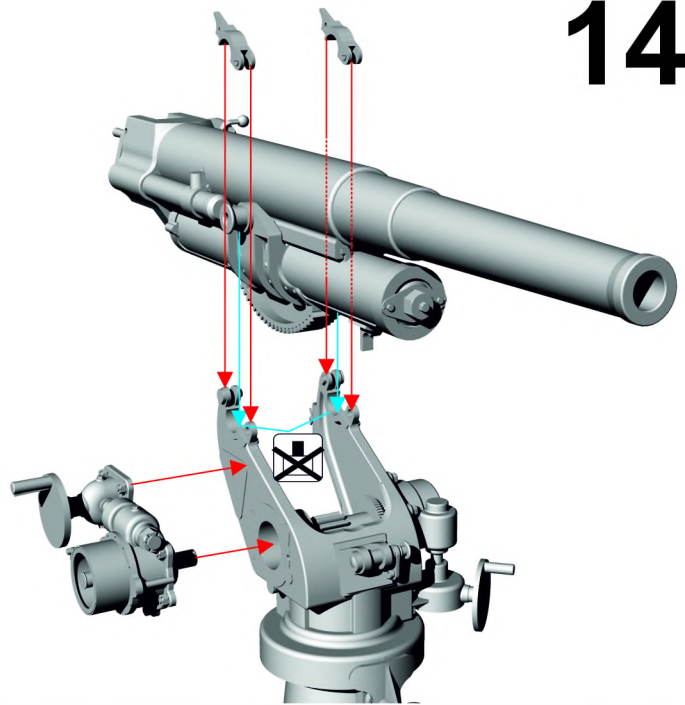

15

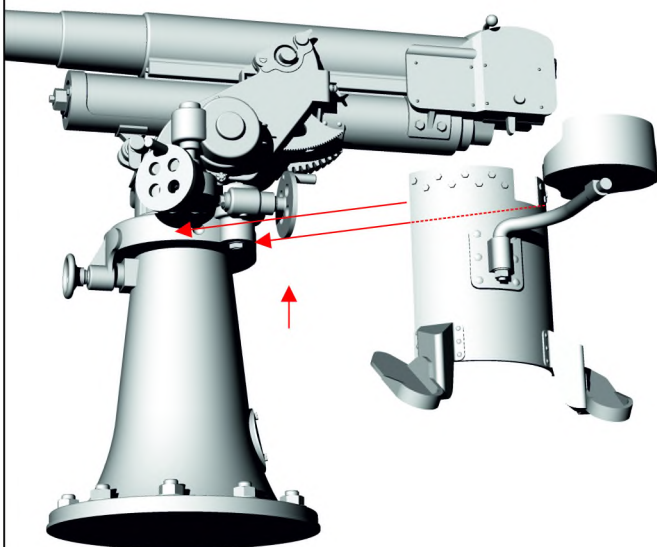

16

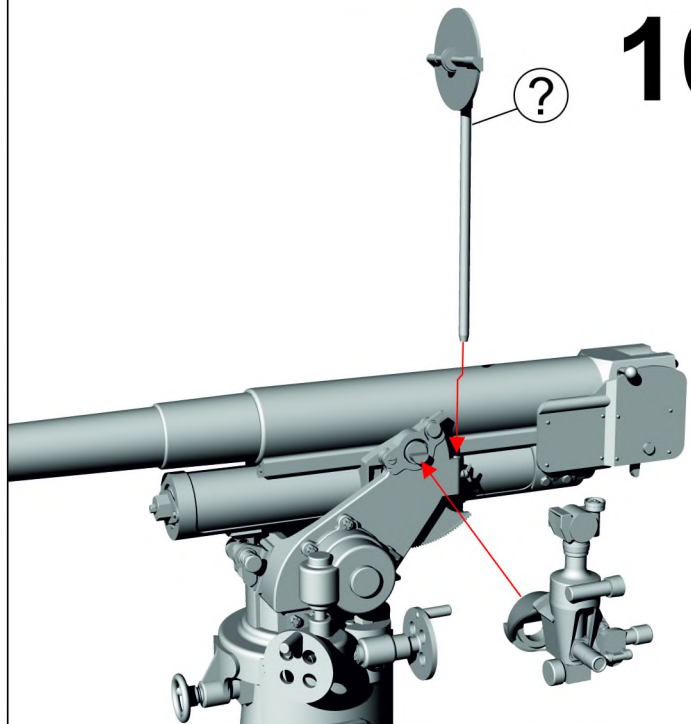



Transport position.
Board closed

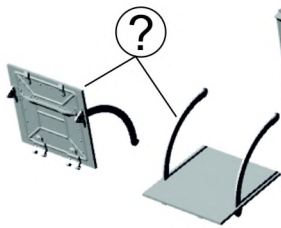

Shooting position.
Board open

17

18

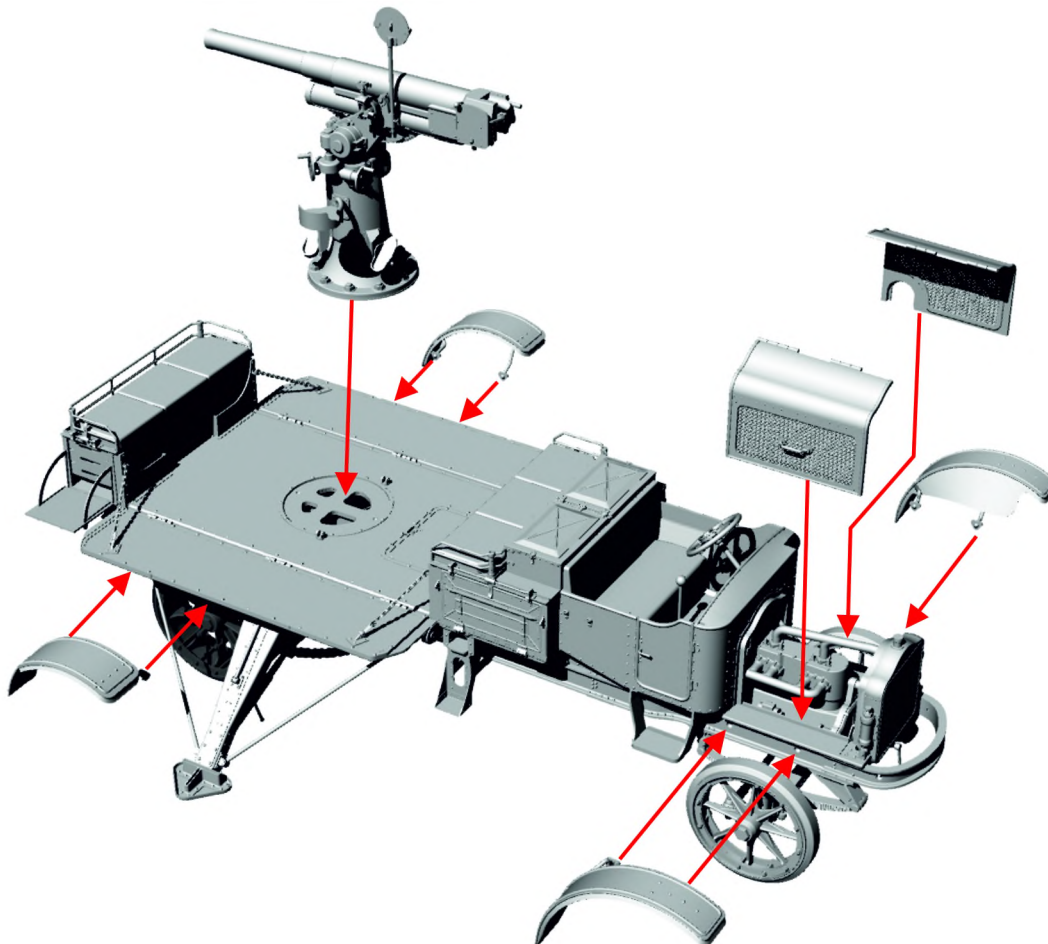

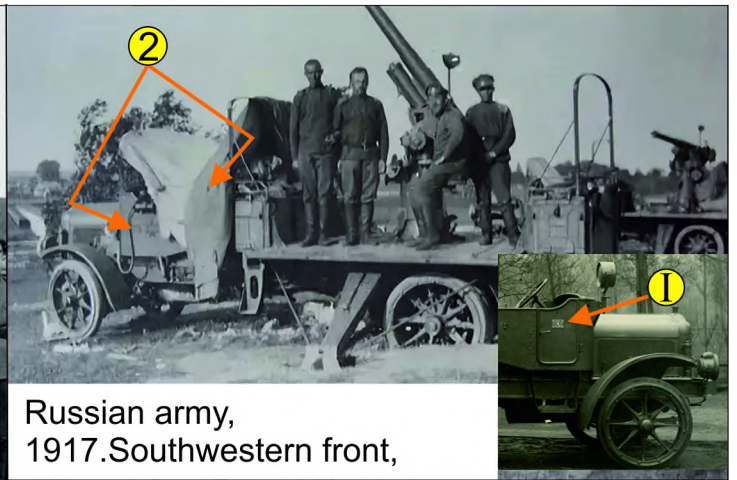
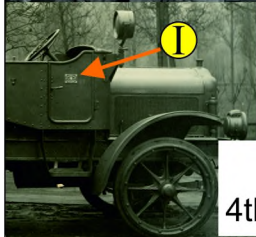
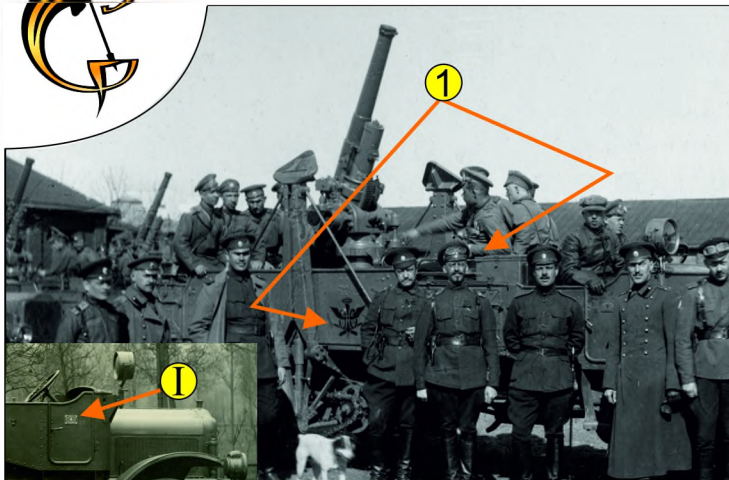

Russian army, 1917. Southwestern front,

Russian army, 1916. 4th battery for firing at the Air Force

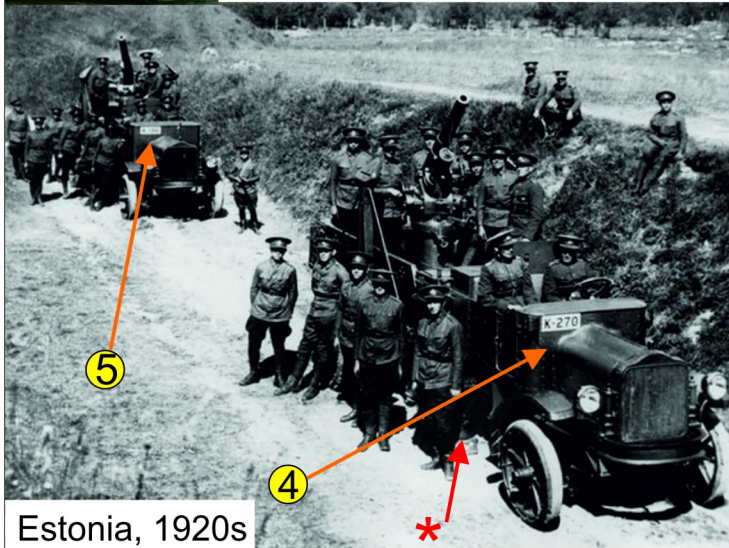

Estonia, 1920s

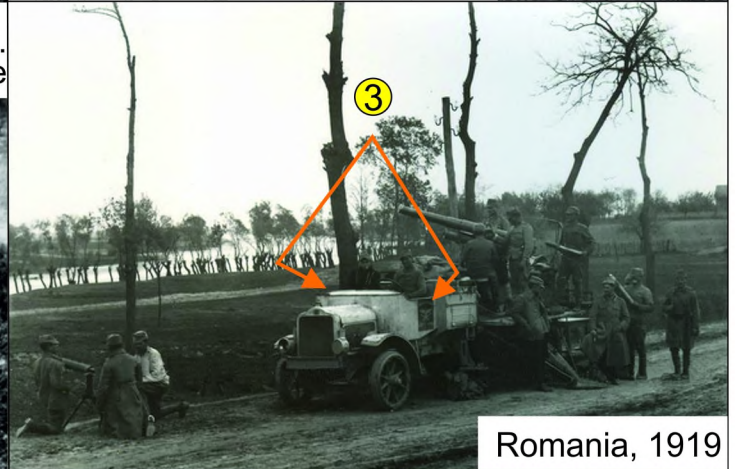

Romania, 1919

Romania, 1924



Red Army, 1920s

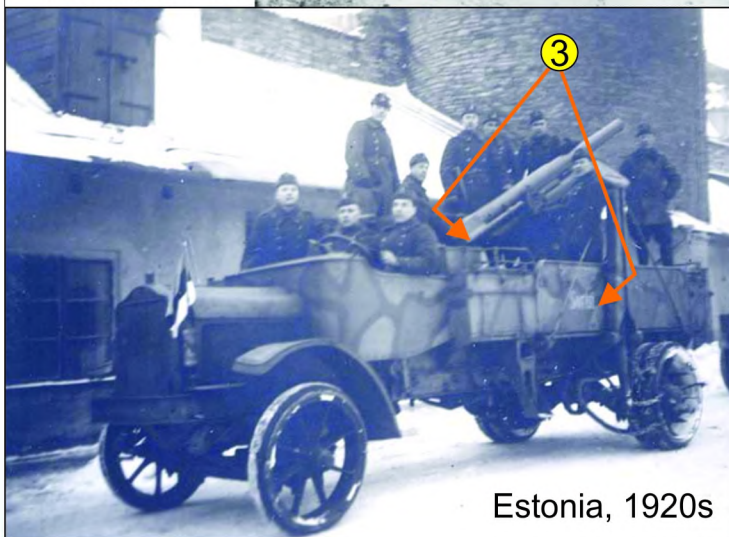

Estonia, 1920s

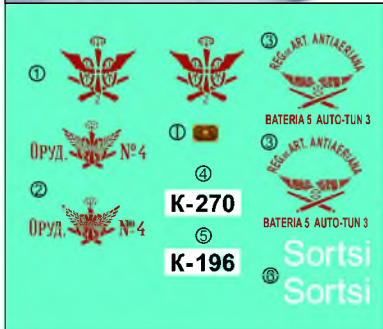

① - for the Russian Imperial Army, 1916-1917
④ - Estonian Army, 20s.
⑤ The cars have been redesigned.
* Additional spacers were installed in the middle of the hull

