



German artillery tractor KD.1

Krupp-Daimler

GM110

1/35

Attention! Some details in the instructions may differ in terms of equipment. These are kits of several individual parts or complex designs with combined parts.

1

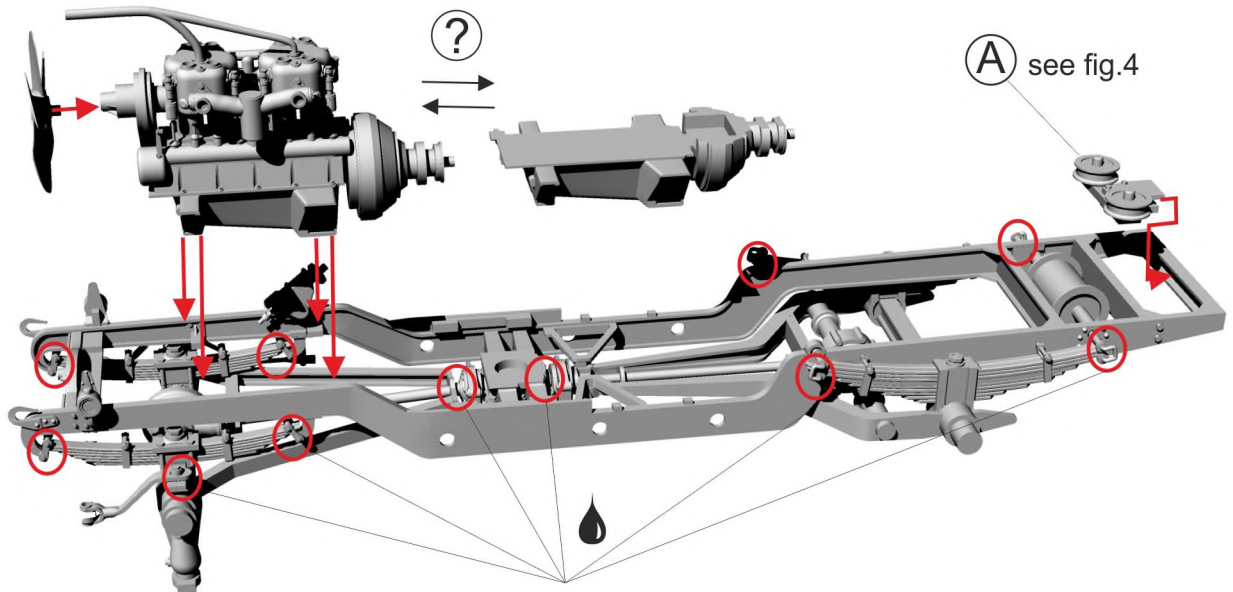

Recommendation. The entire chassis is made in one piece, but consists of several parts. Glue additionally these places.

2

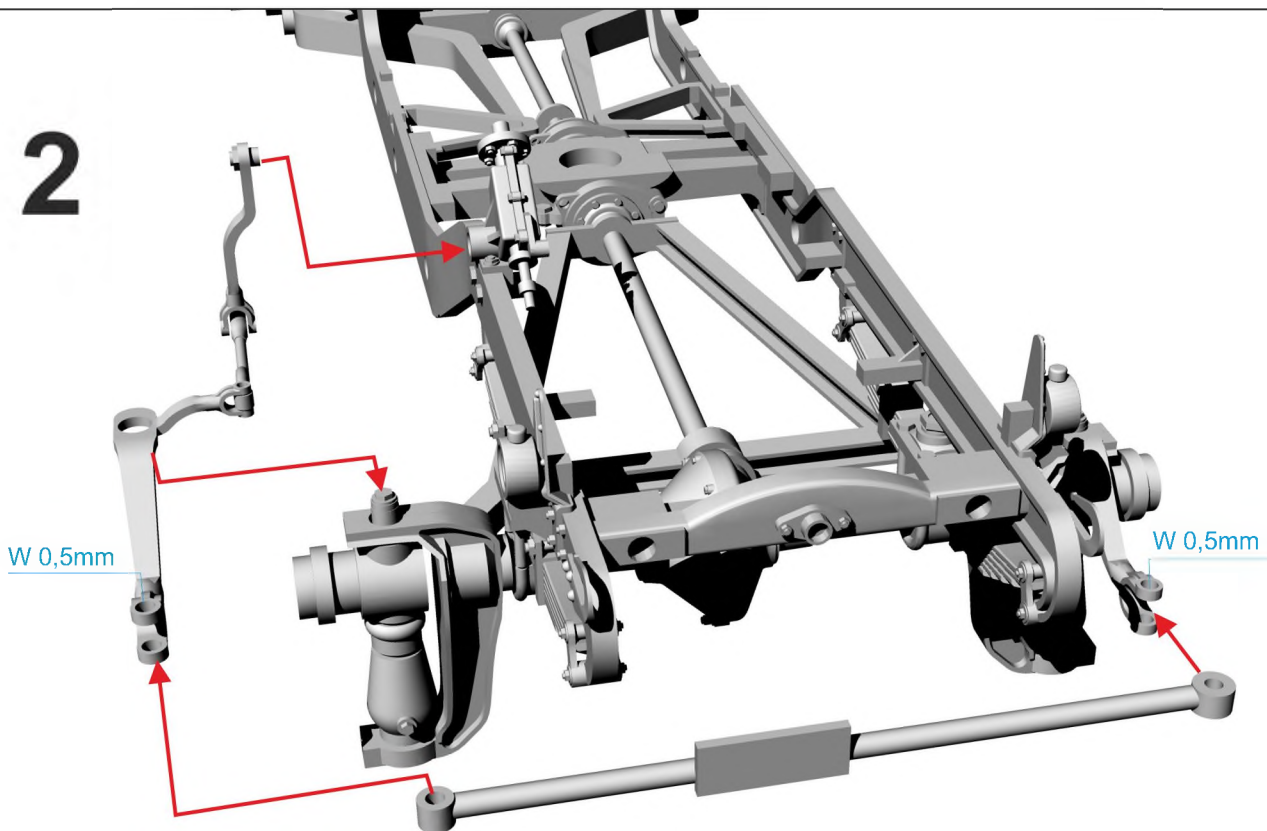



3

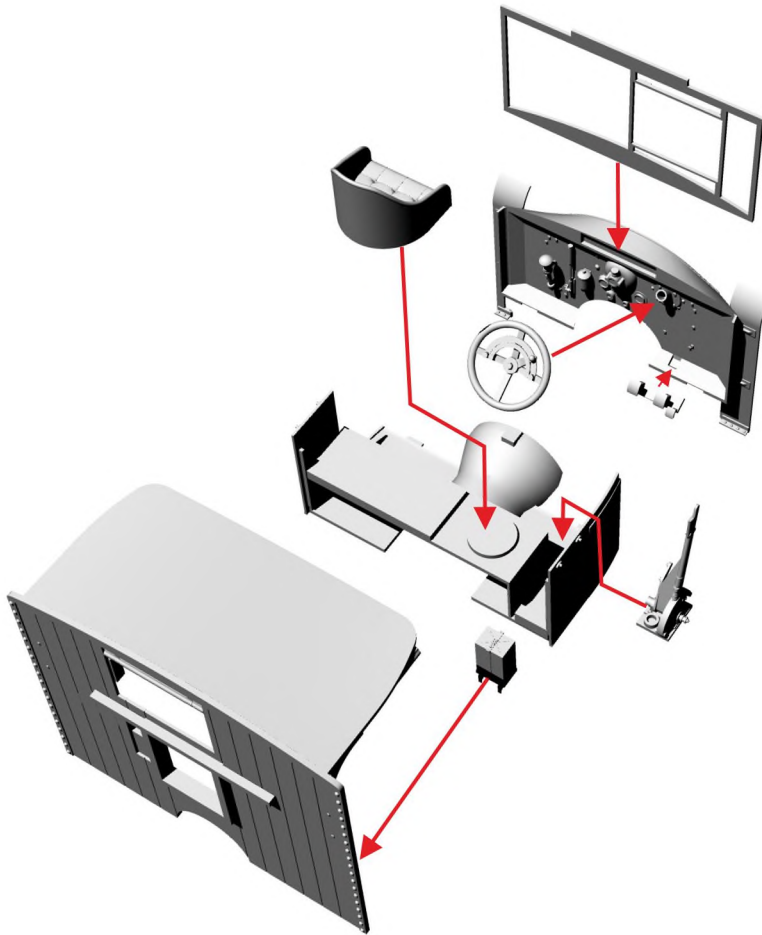

4

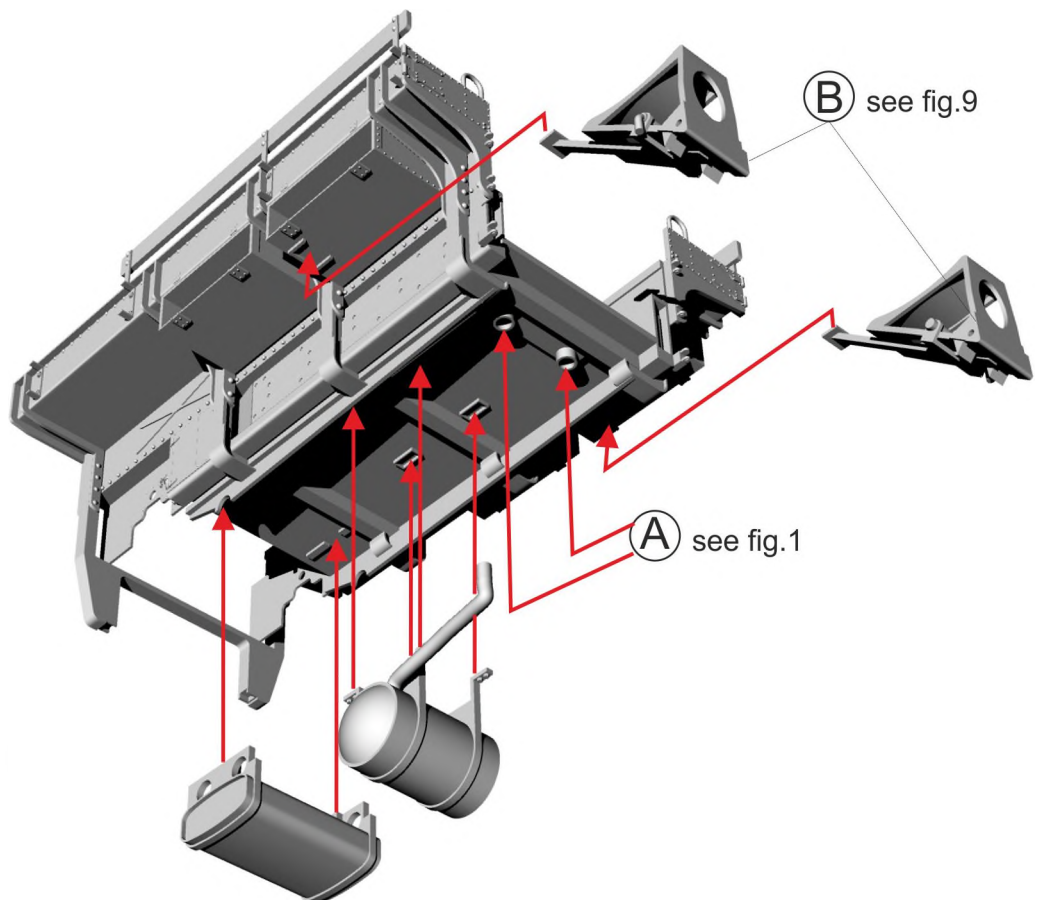



German artillery tractor KD.1

Krupp-Daimler

GM110

1/35

5

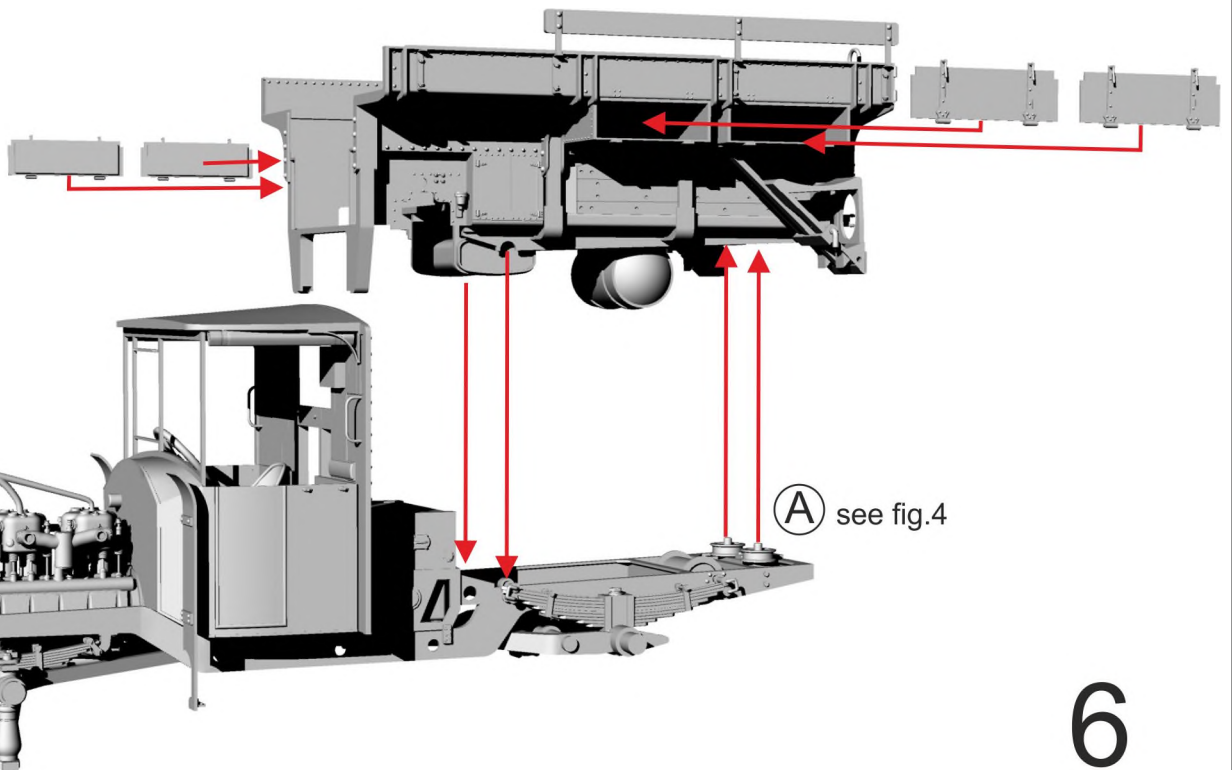
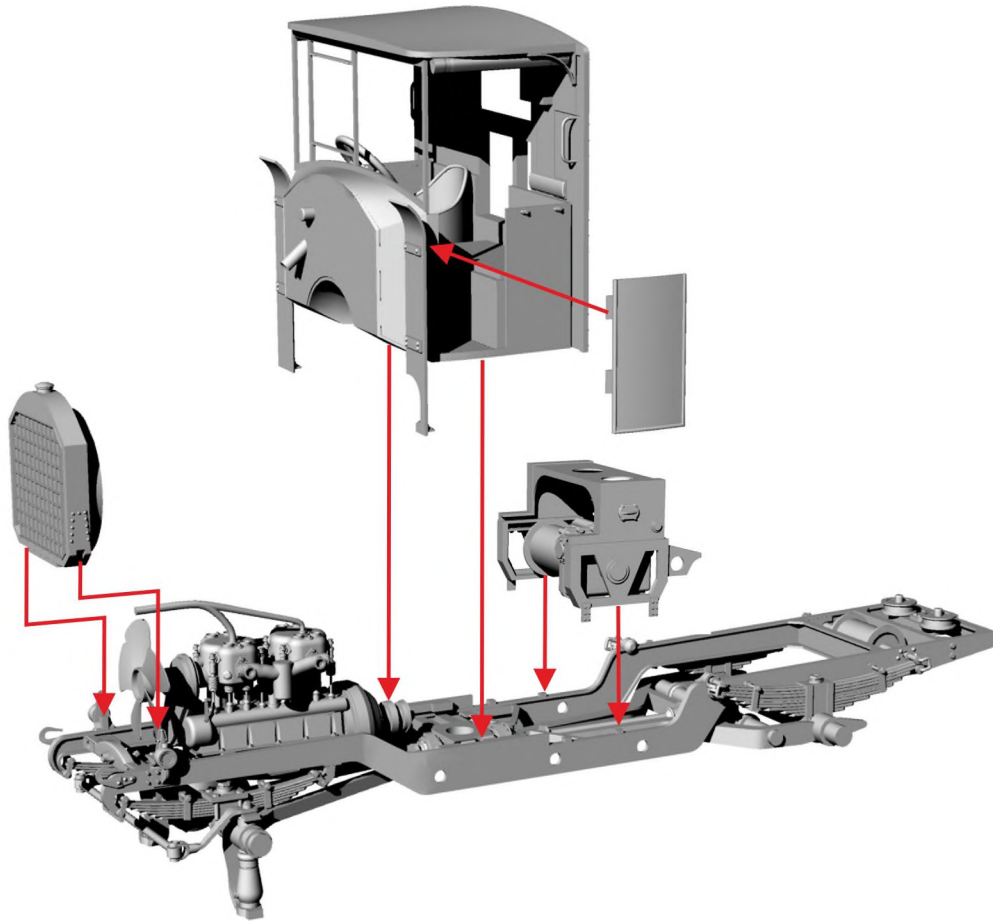

6



Optional: Part was not used on all models.



Do not glue



Glue

W 0,6mm - wire diameter



German artillery tractor KD.1
Krupp-Daimler

GM111
1/35

7

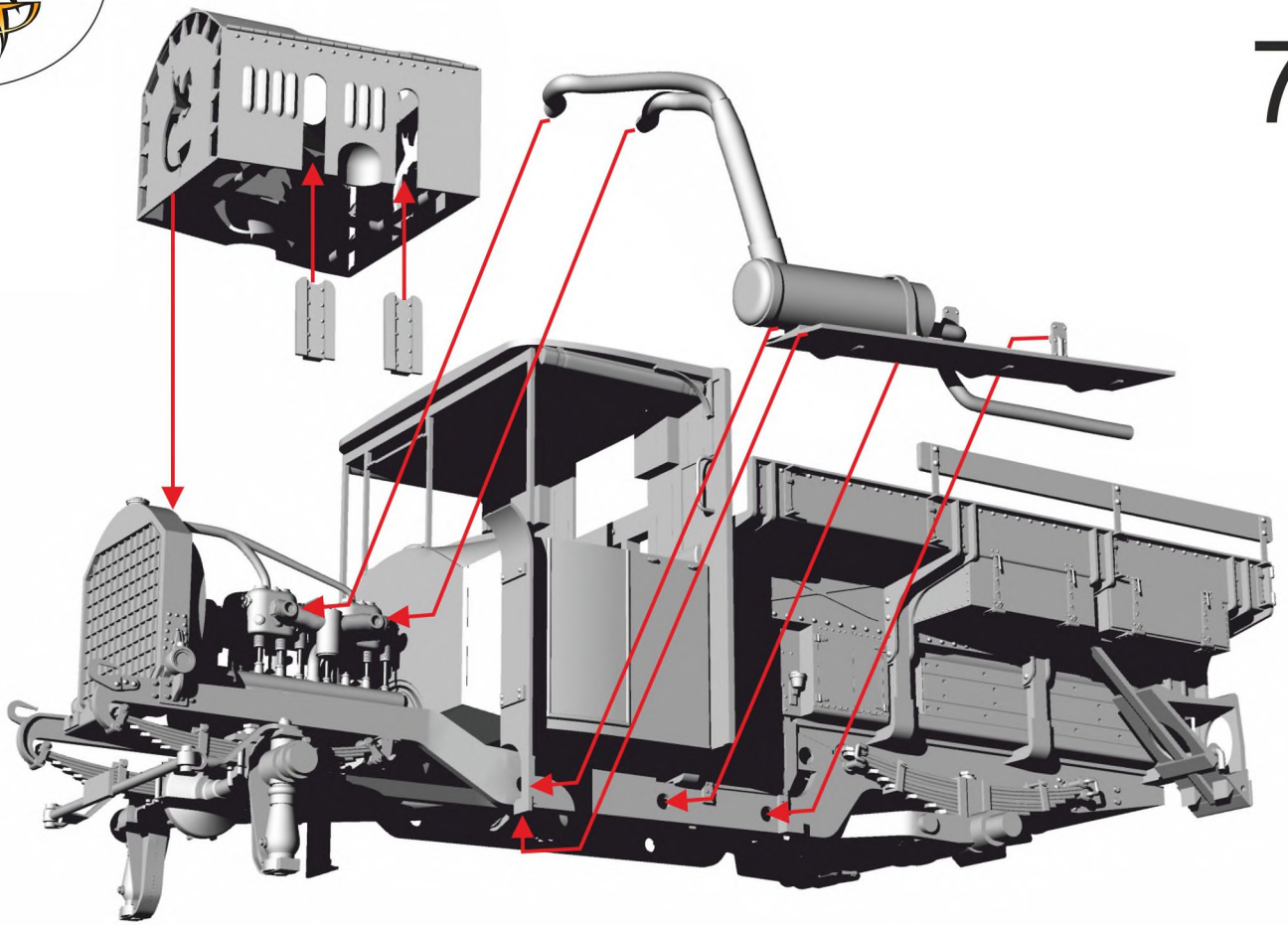

8

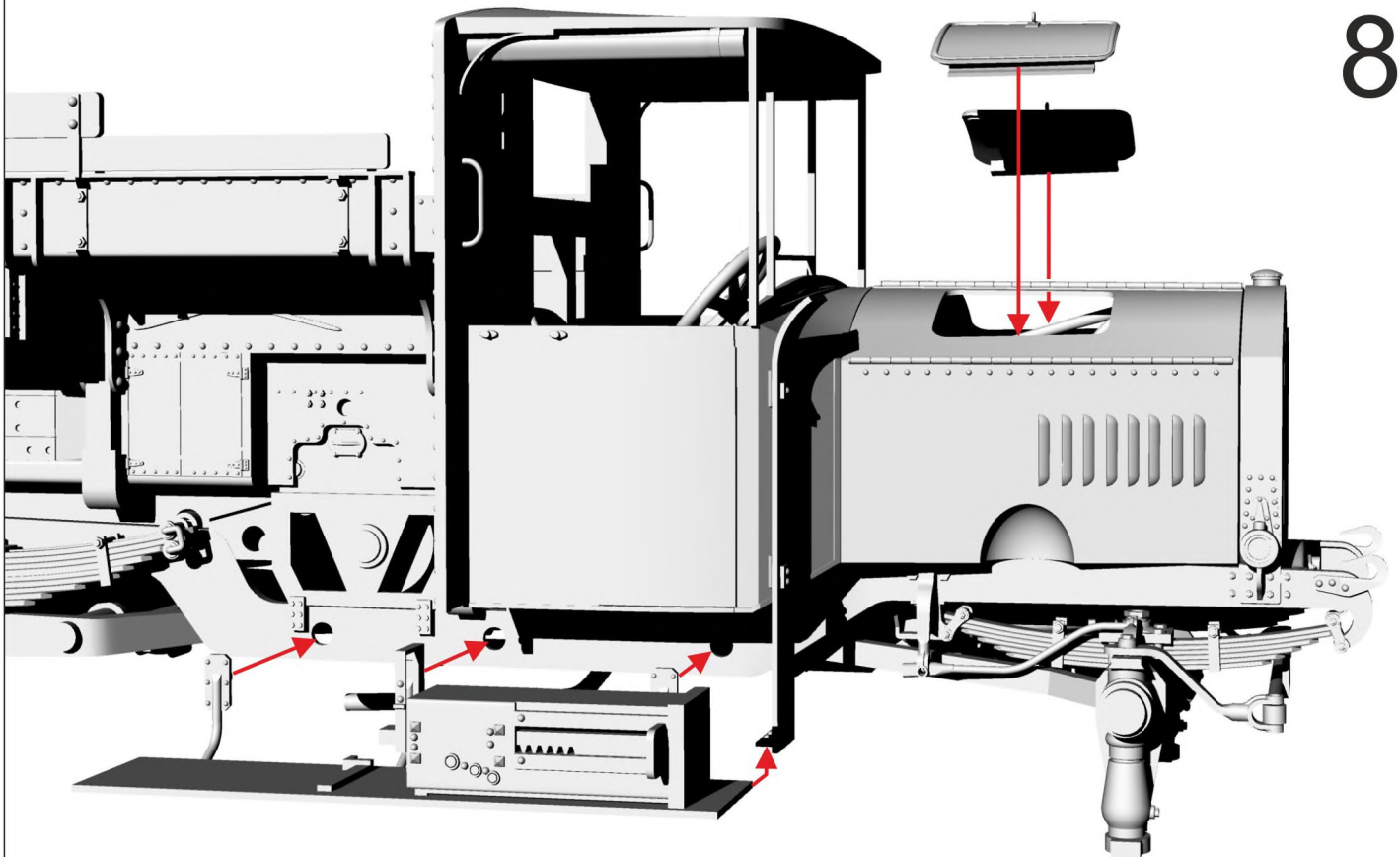



German artillery tractor KD.1
Krupp-Daimler

GM111
1/35

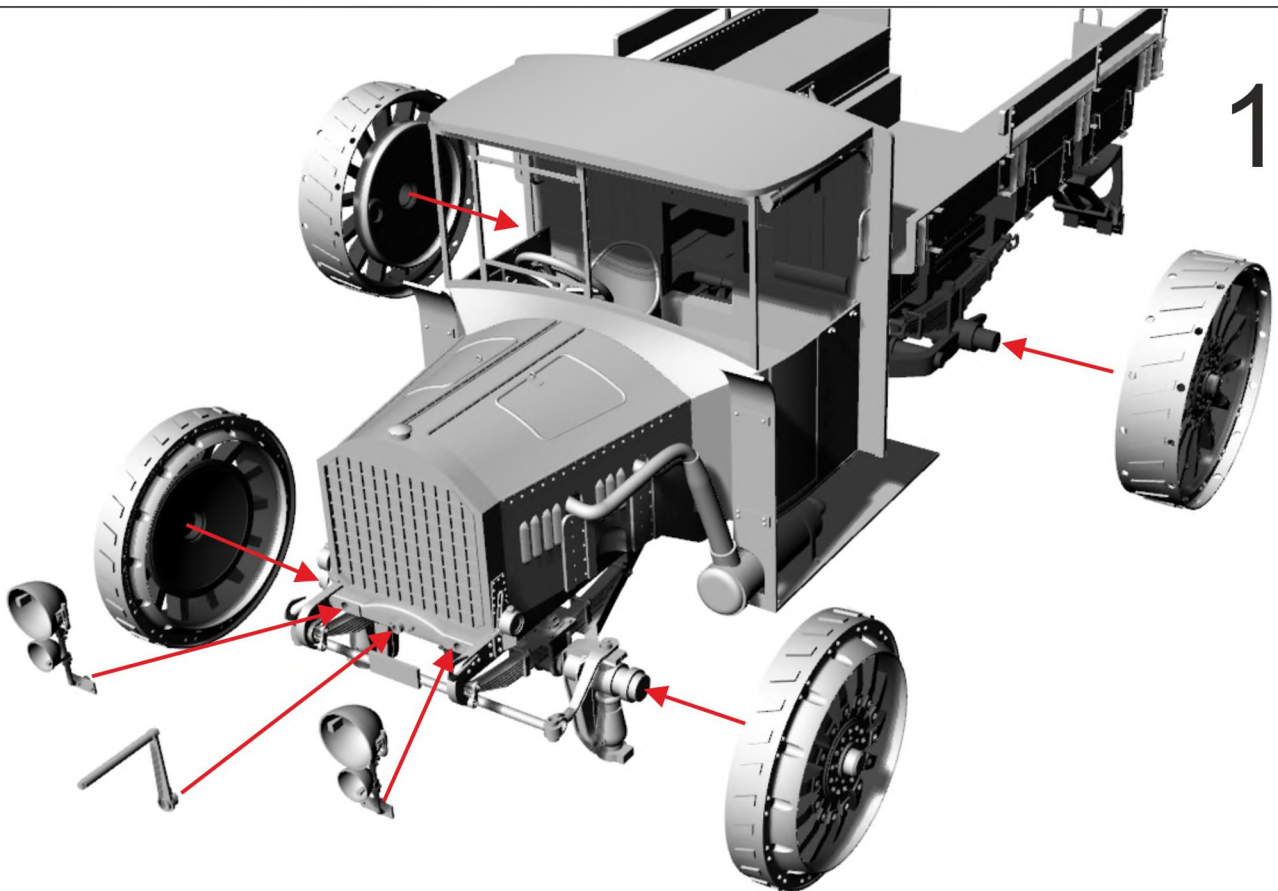
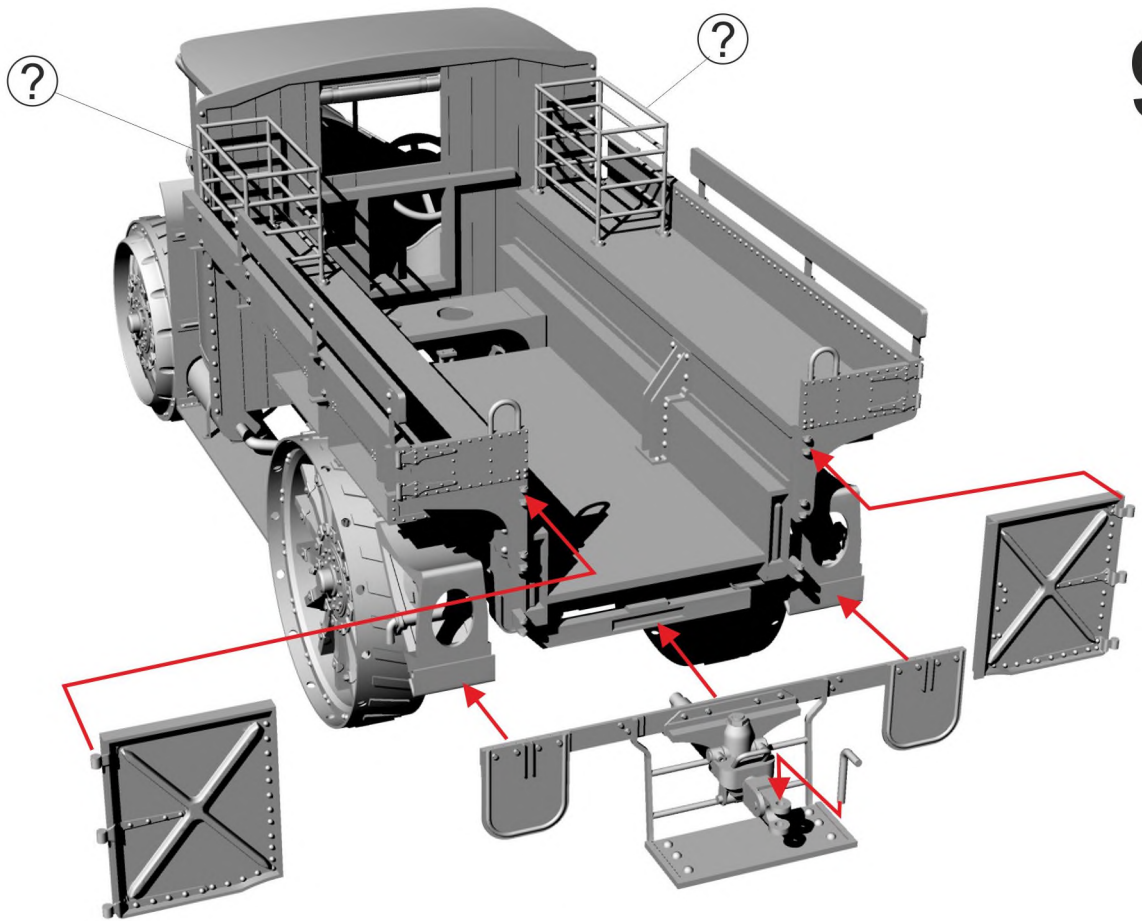



German artillery tractor KD.1
Krupp-Daimler

GM110

1/35

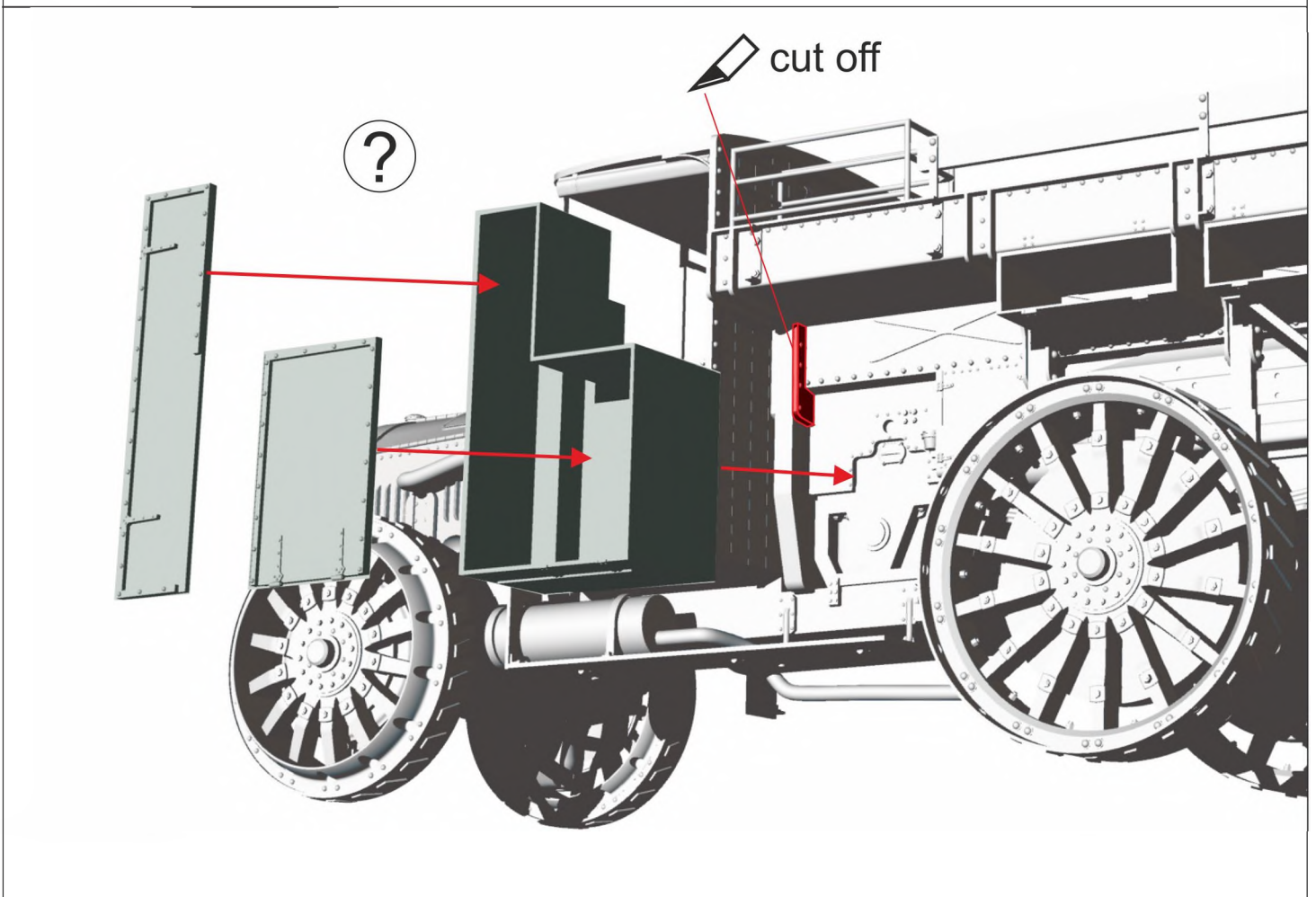
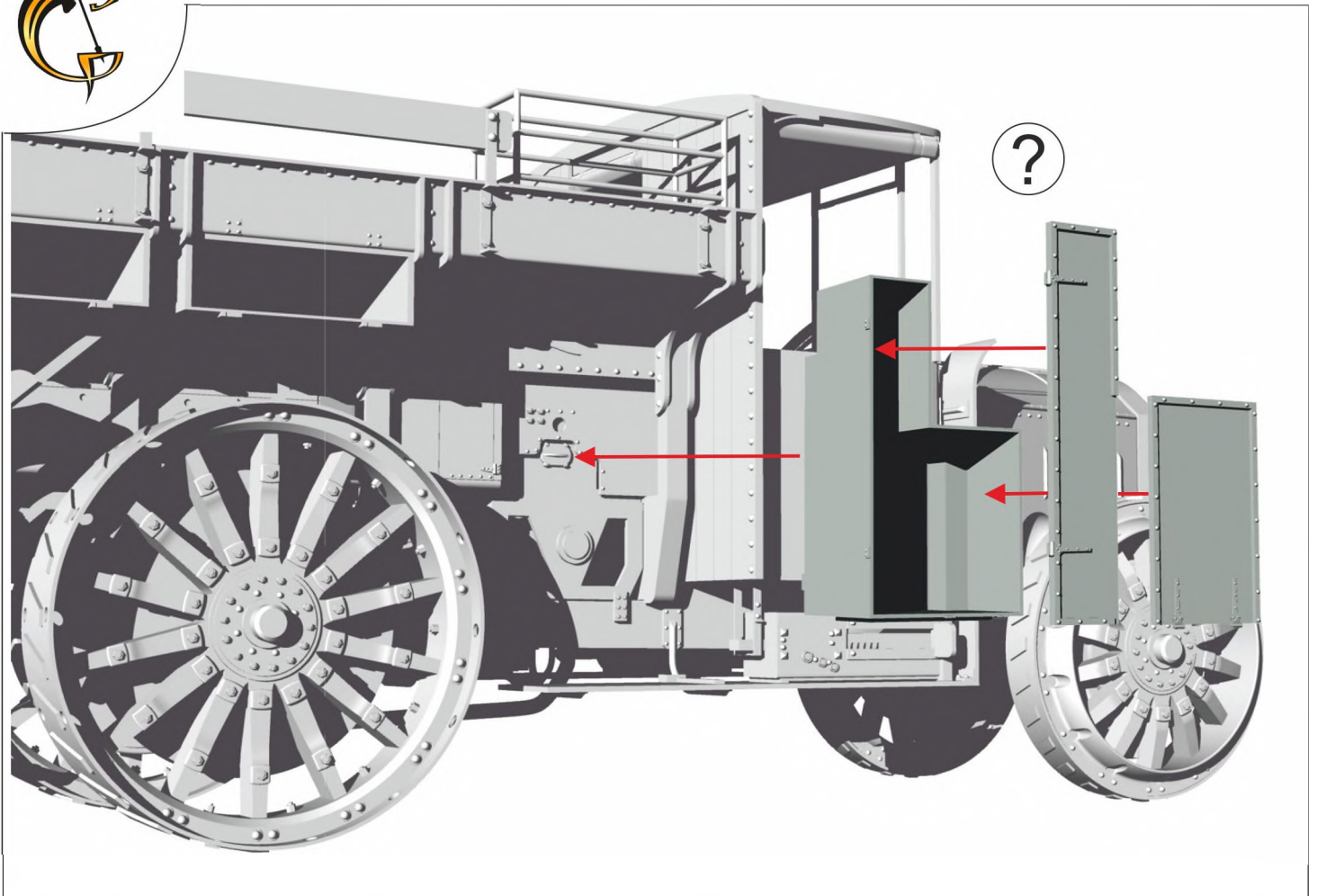



German artillery tractor KD.1 Krupp-Daimler

GM110

1/35

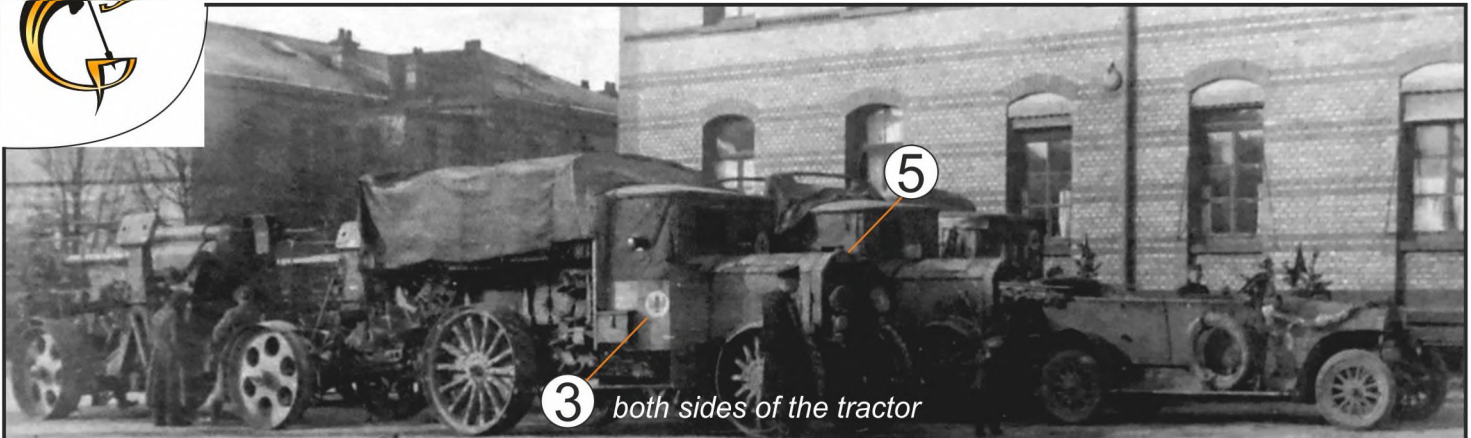

▲
*Schwere Kraftwagen Flak Batterie (Prussian).
Standard emblem of heavy mobile anti-aircraft batteries since mid-1916.*

*Standard lettering on boxes.
KD.1 had several different arrangements of boxes or there were no boxes* ▶

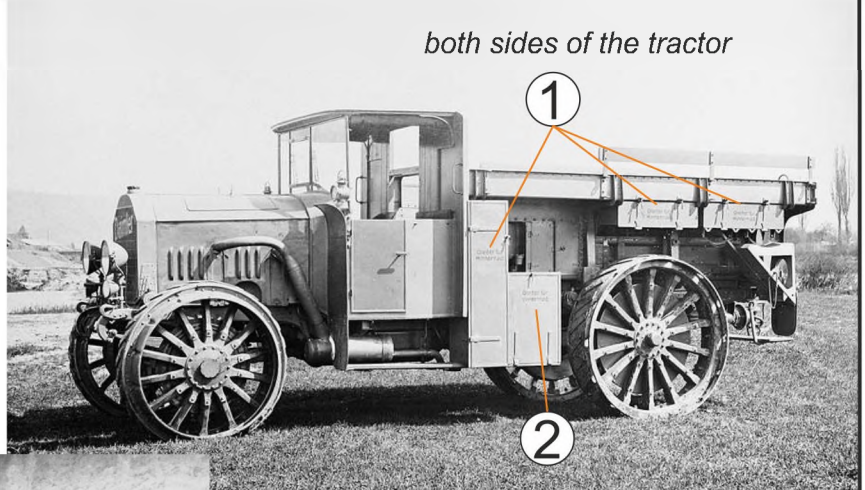

*Schwere Kraftwagen Flak Batterie 147 (Bavarian).
The Bavarians preferred their emblems
The battery was equipped with
8.8cm L/45 Krupp*



▶
*Schwere Kraftwagen Flak Batterie
Unit unknown*



<https://www.facebook.com/artmaquette>
or
artmaquette@mail.ru



German artillery tractor KD.1

Krupp-Daimler

GM110

1/35

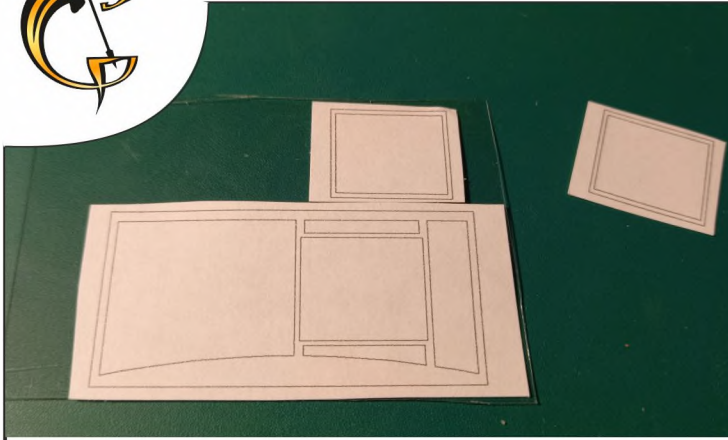

1. Stick self-adhesive on transparent plastic

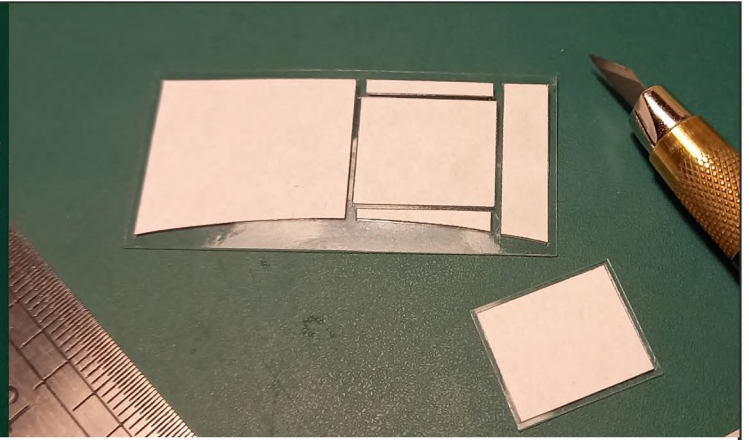

2. Cut along the lines and remove the excess to get a mask

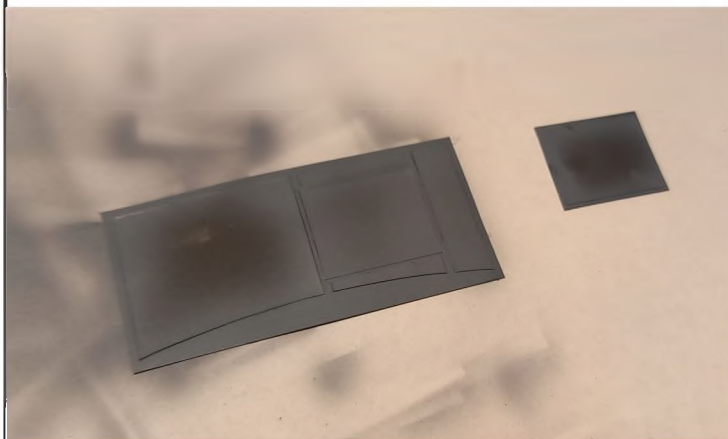

3. Paint with an airbrush

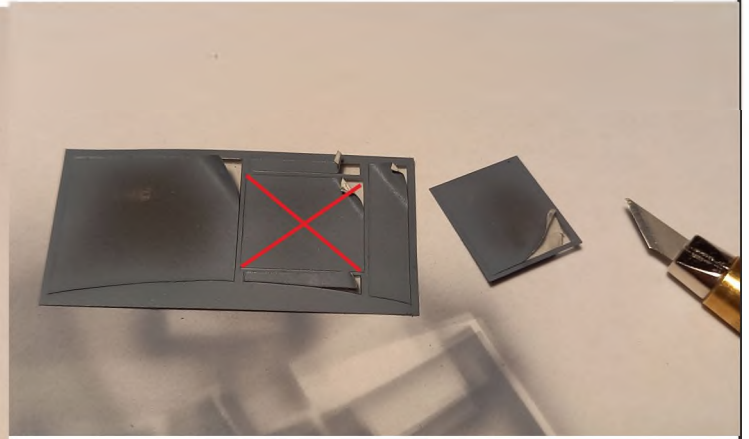

4. Carefully remove the mask. It is better to cut out the place marked with a cross

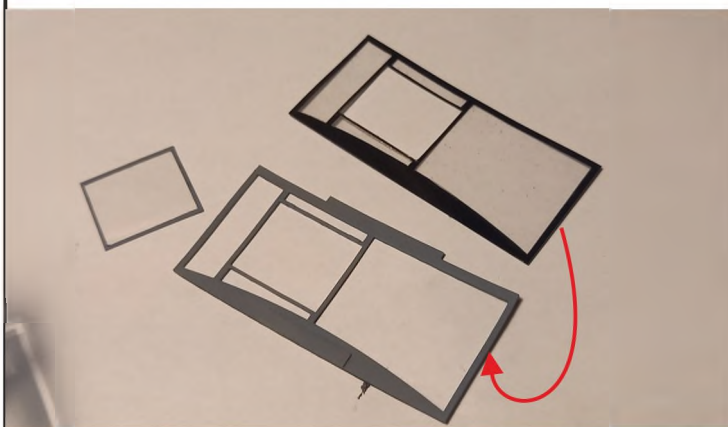

5. Glue plastic to the inside of the same resin part

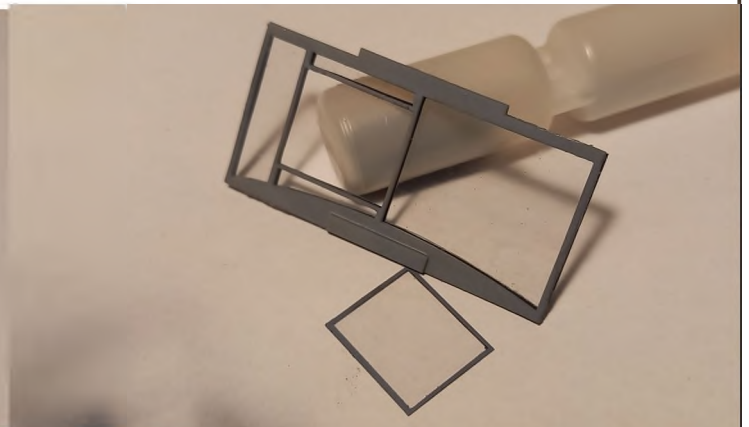

6. Result. Window can be glued in closed or open position